

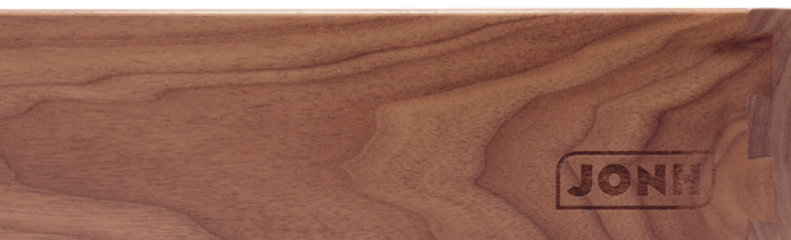

JONH moldings

High-end wood products



Drawers

Catalog 2024

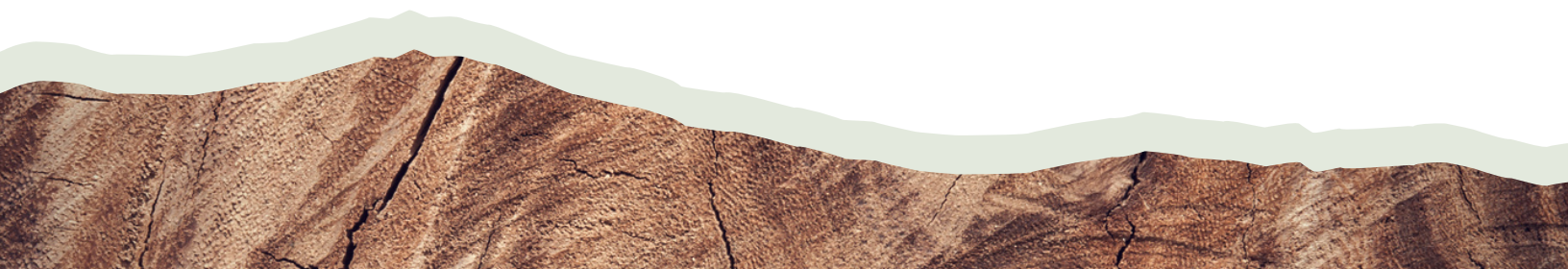

JONH has nearly 20 years' experience in the manufacture of dovetail drawers. Our team will be happy to estimate your projects, answer your questions and advise you, thanks to the experience we've acquired over the years. What's more, to protect the environment, we apply a water-based finish to our drawers.



TABLES OF CONTENTS

Page 4. Wood species

Page 5. Drawer sides - Bottom - Finish

Page 6. Glider grooving

Page 7. Sliding drawer pulls

Page 8. Encoches spéciales

Page 9. Removable drawer dividers

Page 10. Plumbing concealing drawers and V-shaped drawers

Page 11. Accessories

Page 12. Wood dividers



Wood species



Natural yellow birch



Natural Maple



Yellow Birch



Maple



Walnut



White oak

Other species available on request

Choice of drawer sides

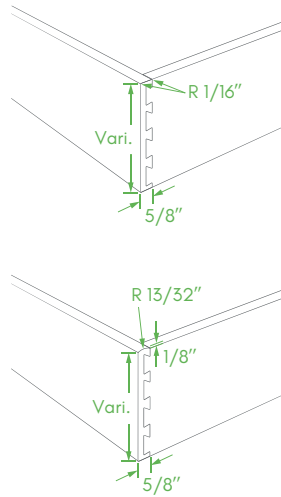

TC 5/8

- Standard drawer side
- 10 working days lead time

Note that the side is the same height as the front.

TR 5/8

- Standard drawer side
- 10 working days lead time

Note that the side is 1/8" lower than the front.

Bottom thickness

Our drawer bottoms are standardized. Only one choice is available:
- 3/8" MDF veneer

Logo

We offer the option of having your logo laser-engraved on your drawers, ensuring a perfect "look".

Drawer finish

The finish we offer on our drawers is a water-based varnish. We apply two coats, and sand the finish between each coat to optimize product quality. For walnut and white oak, three coats are applied.

Glider grooving

Back grooves

C2

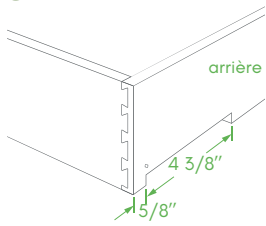

C5

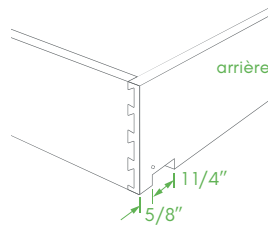

C6

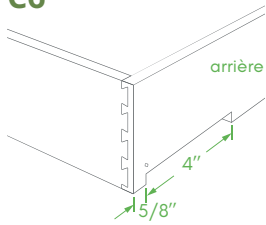

C30

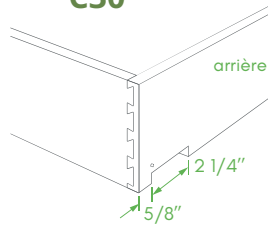

Forward grooves

C4

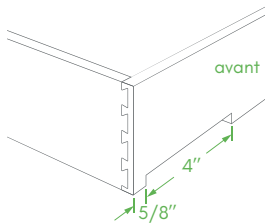

C10

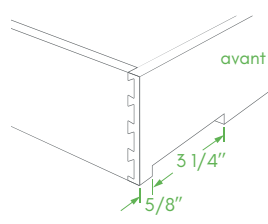

Back/forward grooves

C54

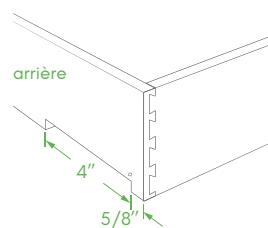
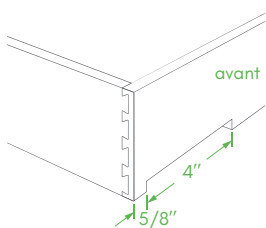

C40 Combine grooves C10 and C30

Clips installation

We can install glider clips on your drawers. We install the following clips:

Movento Blum



Tandem Blum

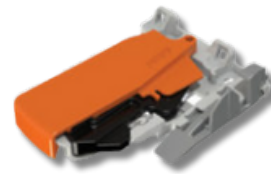

Hettich 5D



Sliding drawers pulls

C14

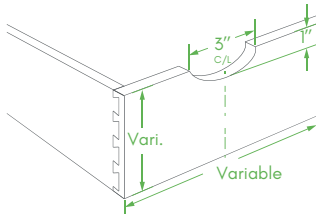

C15

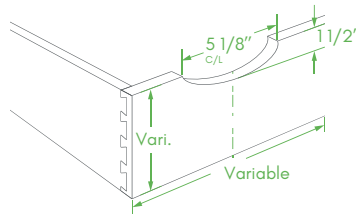

C17

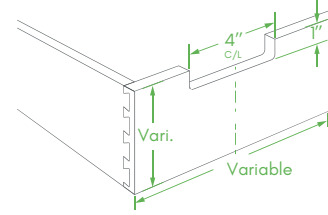

C18

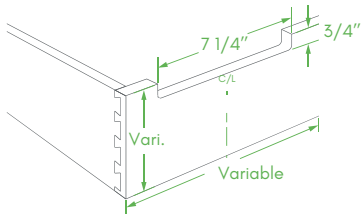

E2

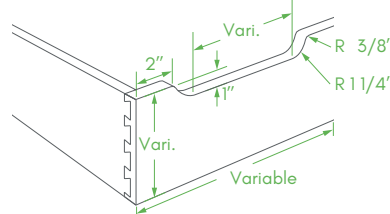

P1

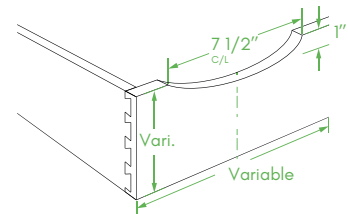

C16 - option

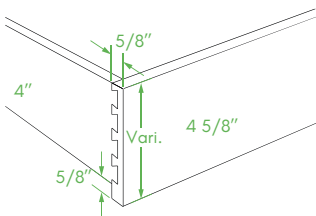

Option C16 allows to camouflage the gliders so that they are not seen when facing the drawer. The drawer front is 5/8" higher than the sides. It can be combined with any of the above options.

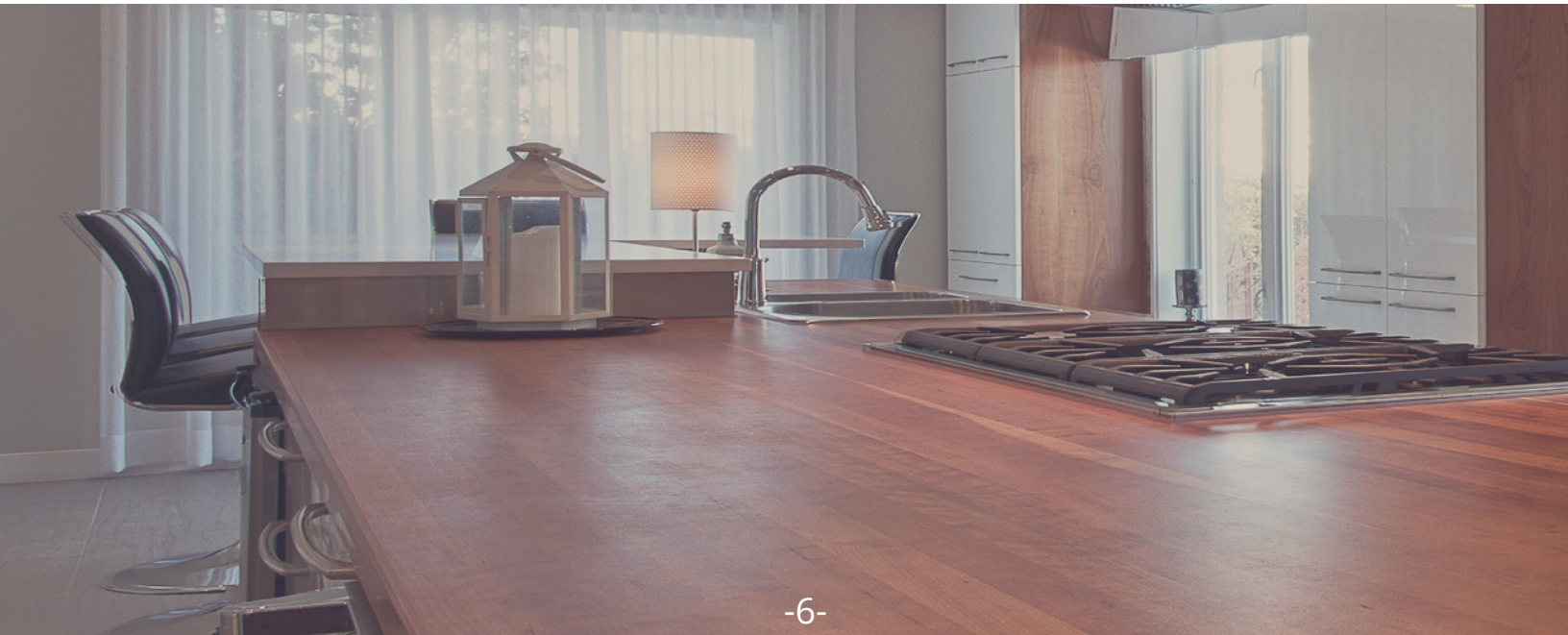

Special grooving

C1

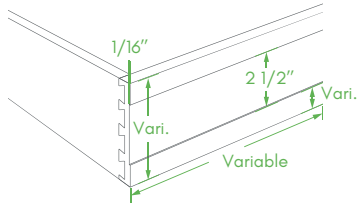

Option C1 is a groove performed in the front portion of the drawer in order to allow the addition of a “clip” to adjust the drawer front. Option C1 can also be paired with option C12.

C12

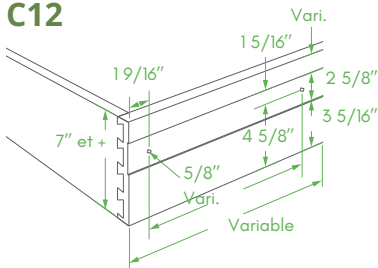

Option C12 is a hole used to adjust the drawer front. This option needs to be paired with option C1.

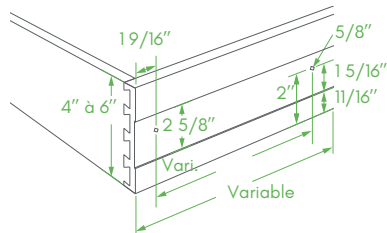

Drawers with removable dividers

DCOA

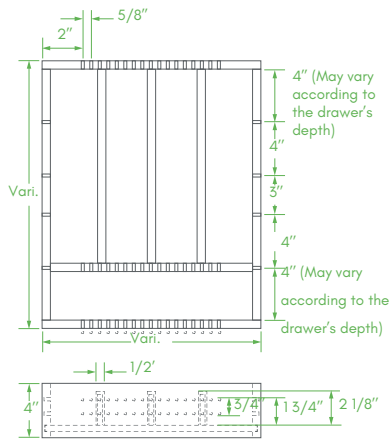

DCOB

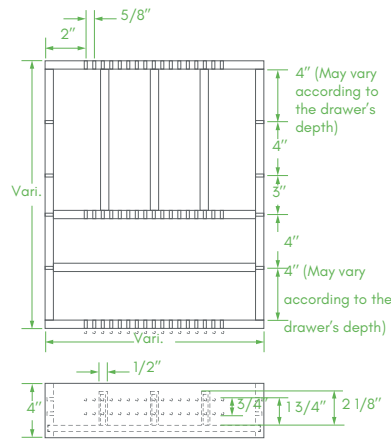

DCOC

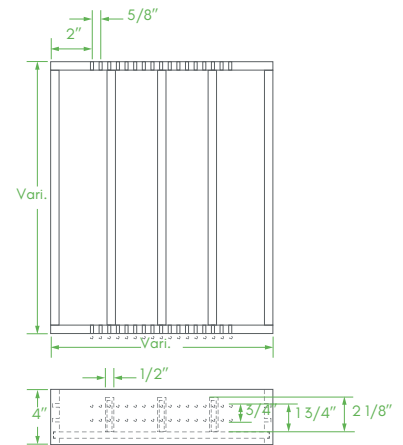

The drawer's width will determine the number of dividers. You may, however, choose the number of dividers that you want

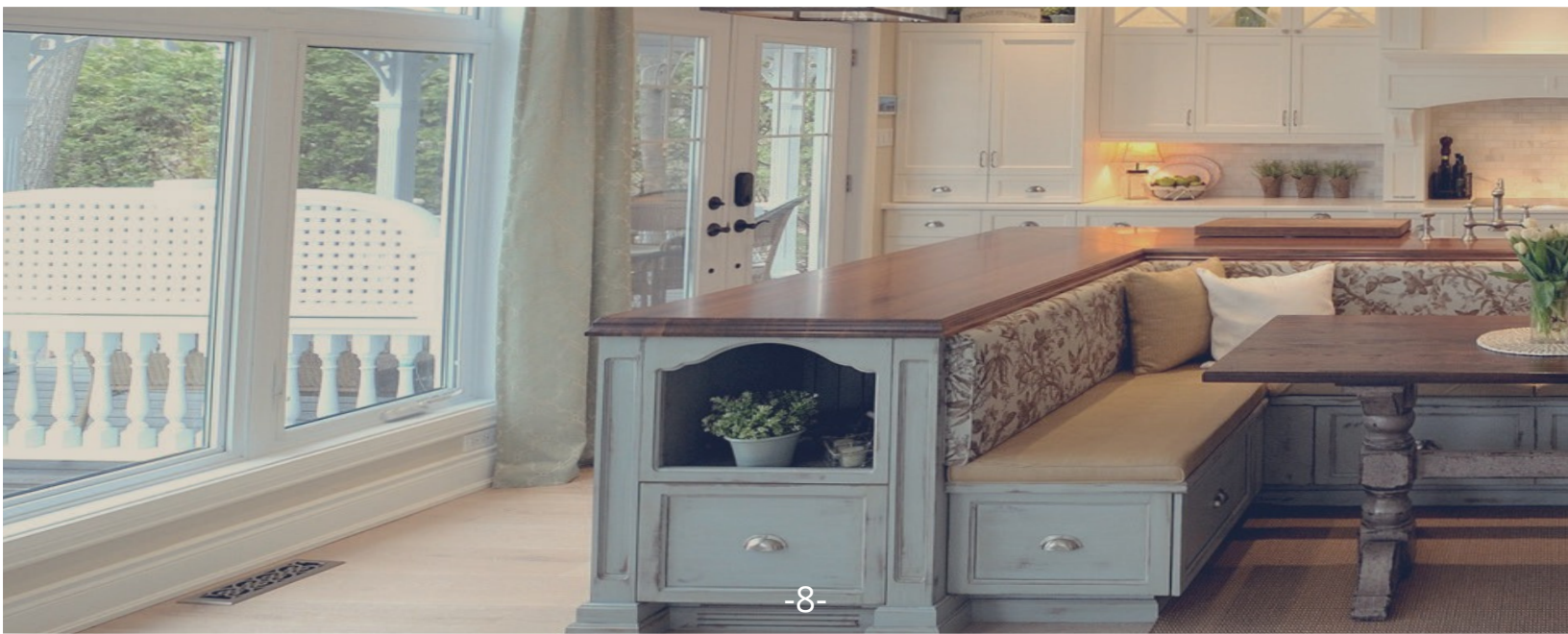

Special drawers

"V" shaped drawer

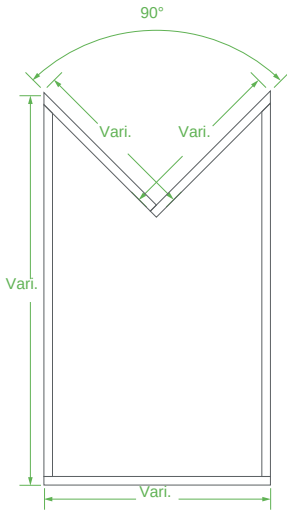

- Variable drawer heights and sizes
- Dove tail assembly

Plumbing concealing drawer

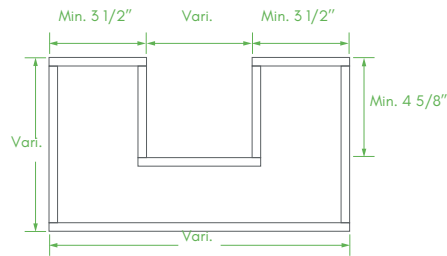

- Variable drawer heights and sizes
- Dove tail assembly

Bombe drawer

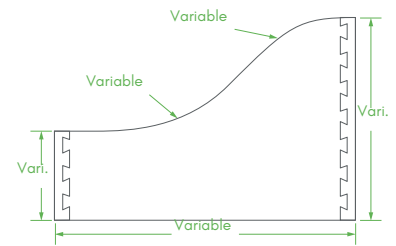

- Variable drawer heights and sizes
- Dove tail assembly

Drawer with pegs

- Variable drawer heights and sizes
- The number of pegs is variable. They are removable.
- Dove tail assembly

The drawer's width will determine the number of pegs. You may, however, choose the number of pegs that you want

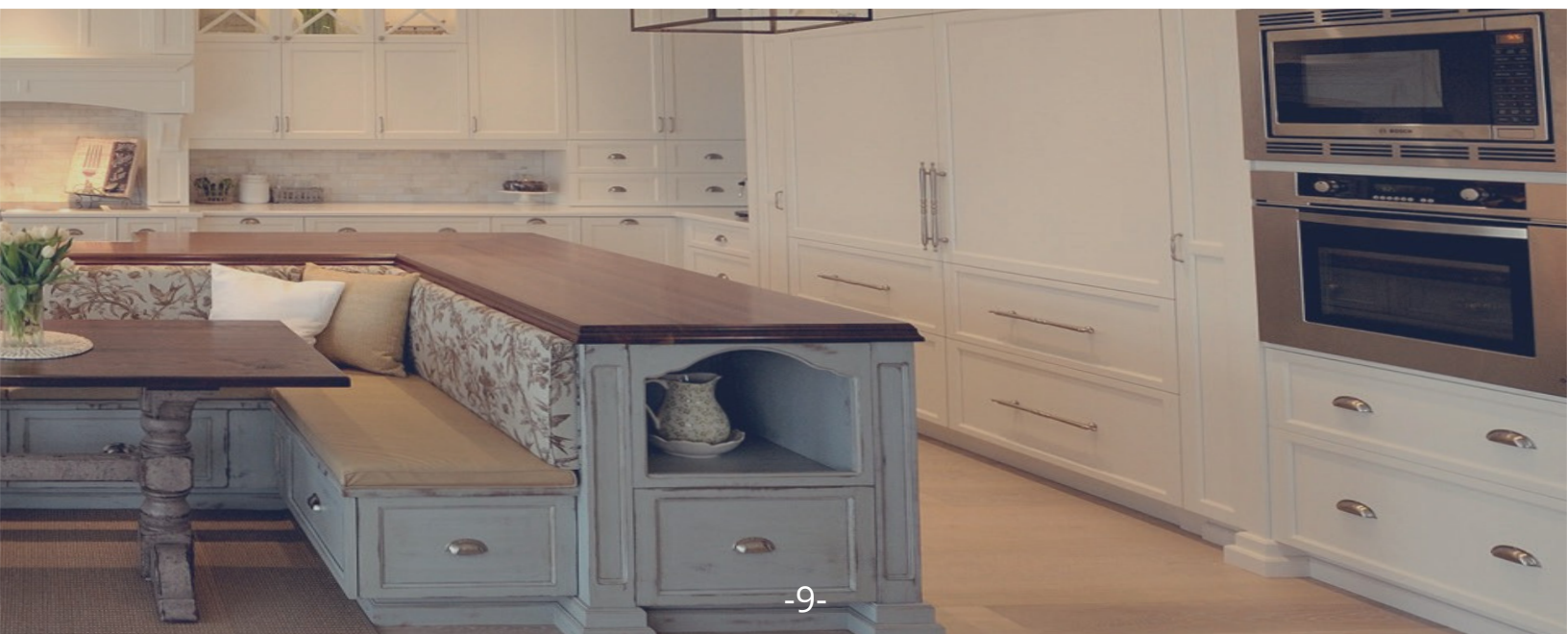
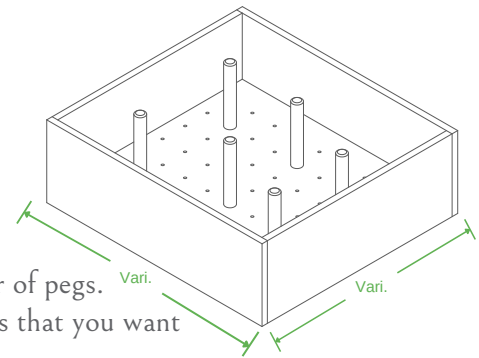

Accessoires

KNIFE BLOCK

- Custom sizes
- Variable number of knife slots
- Optional varnished finish

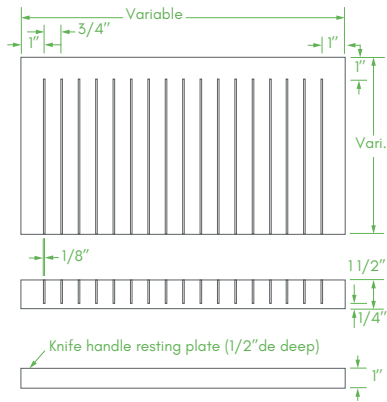

SPICE RACK

- Custom sizes
- Number of racks adjusted according to the drawer's depth
- Can be sold according to the rack's length
- Optional varnished finish

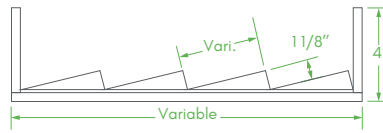

FIXED DIVIDERS

- Custom-made to your plans
- Dividers are 1/2" thick and 1/8" recessed in height
- Optional varnished finish

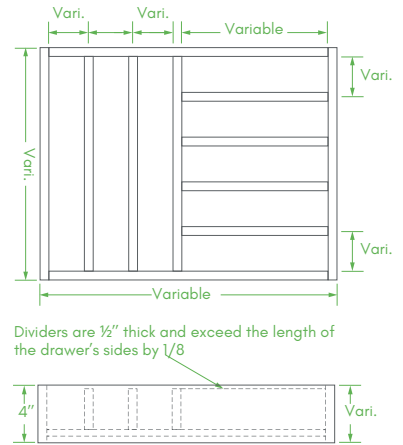

WOODEN DIVIDER BLOCK

The dividers are custom made in order to offer you maximum freedom of choice. Available heights vary from 1 21/8" to 2 21/8". You may choose between maple, walnut and yellow birch woods. We also offer a two-coat water-based varnish finishing option.

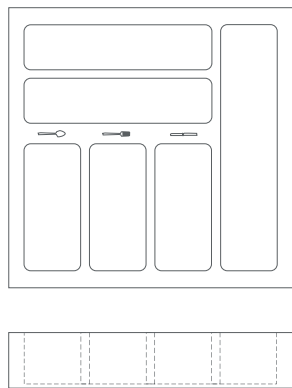

TIROIR DIVISEUR DOUBLE

The dividers are custom made in order to offer you maximum freedom of choice. Available heights vary from 1 21/8" to 2 21/8". The divider's height can be adjusted to fit your drawers' height. You may choose between maple, walnut and yellow birch woods. We also offer a two-coat water-based varnish finishing option.

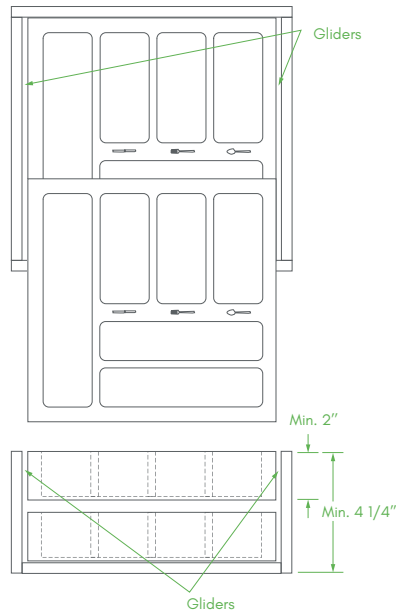

STORY

In 1979, founder J.O. Noël Houle launched the family business, which at the time focused on the drying and sale of hardwood to cabinetmakers in the region. The quality of its products and service have enabled the company to carve out a place for itself as one of the leading suppliers of quality wood components in the Quebec region and in certain Canadian provinces.

Since the 2000s, the manufacture of mouldings, wood components, countertops and drawers has been at the heart of the company's development, enabling it to maintain an enviable position in the industry.

ENVIRONMENTAL PHILOSOPHY

At JONH, the environment and the preservation of resources are important issues. The choice of top-quality materials used in the manufacture of moldings and high-end kitchen cabinet components ensures that they will last longer. We strive to reduce over-consumption by offering products that stand the test of time. What's more, processing residues are recovered and transformed into animal absorption products and combustible materials.

MISSION

A job well done, the long-term sustainability of our products and respect for the materials we process are the foundations of our company. We like to enter into lasting partnerships with our suppliers and customers. The satisfaction and loyalty of our customers and partners are fundamental to our corporate strategy.

Our passion, our expertise, your satisfaction

4700, Sainte-Catherine
Sherbrooke (Quebec) J1N 0E7
819-864-6273
1-800-565-6273
Fax 819-864-7612
www.mouluresjonh.com

