

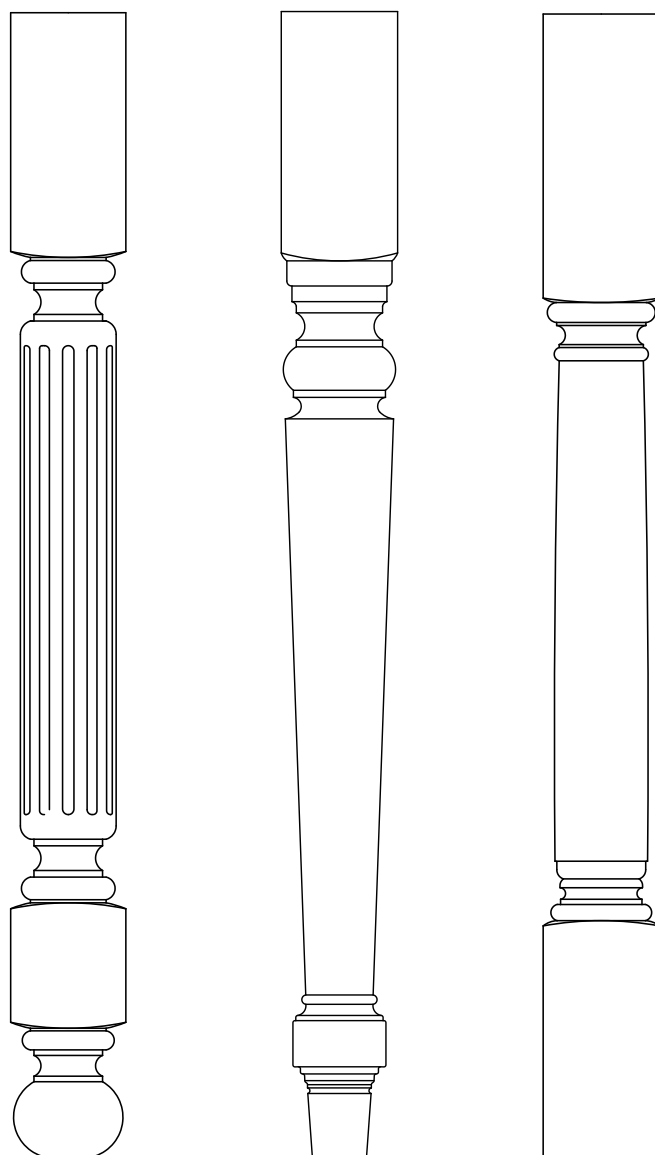

JONH moldings

High-end wood products



Legs
Catalog 2024

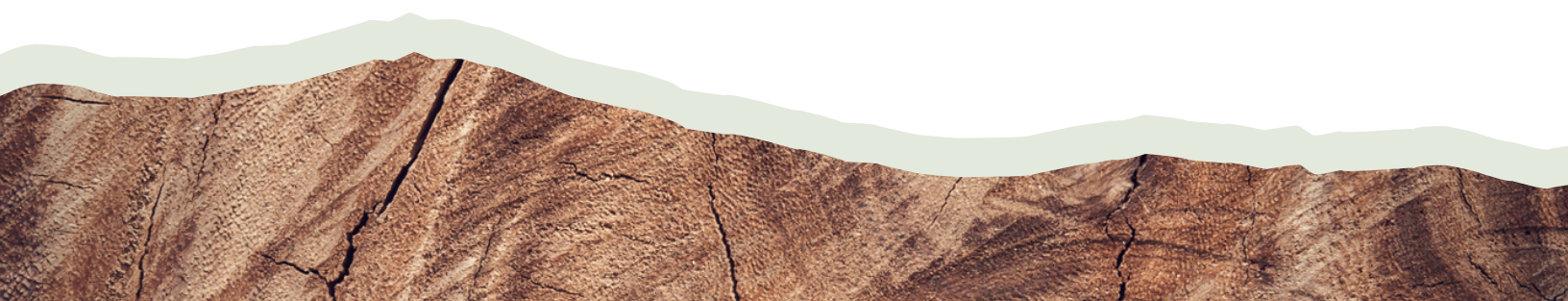

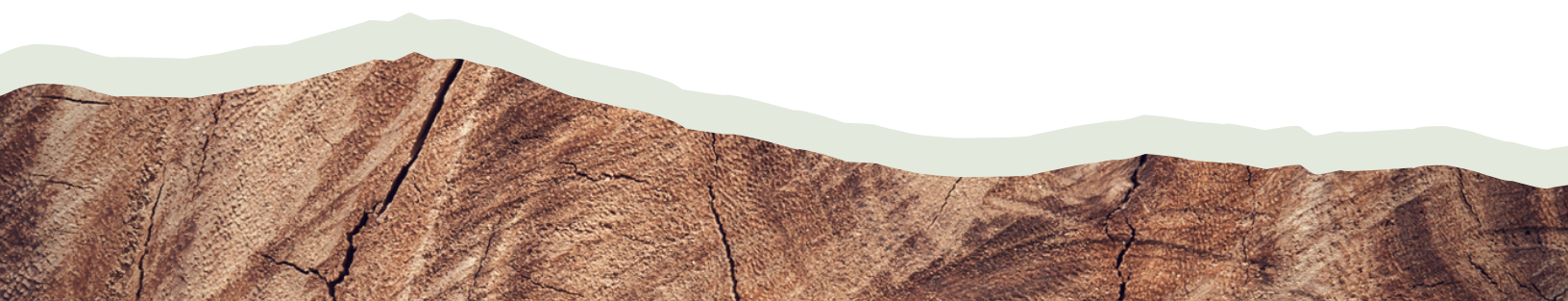

TABLE OF **CONTENTS**

Page 4-6. Turned legs

Page 7-8. Bunfeets

Page 10. About



Turned legs

Available sizes

3" x 3"

3 1/2" x 3 1/2"

4" x 4"

Height : 28 1/2" à 42"

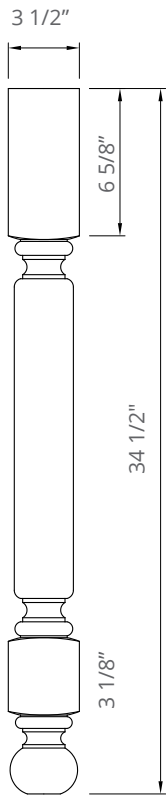

#P100 (JONH #301)

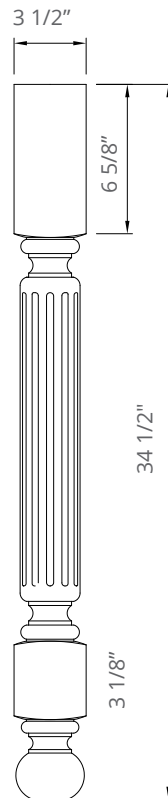

#P101 (JONH #302)

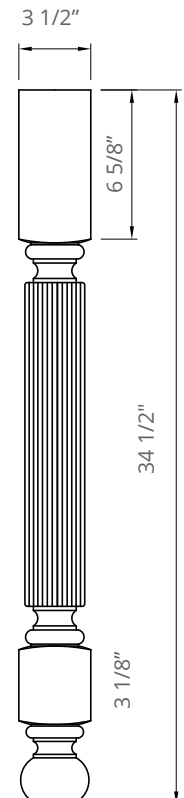

#P102 (JONH #303)

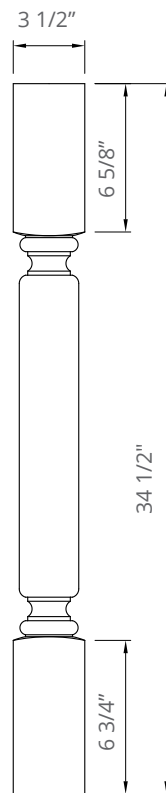

#P200

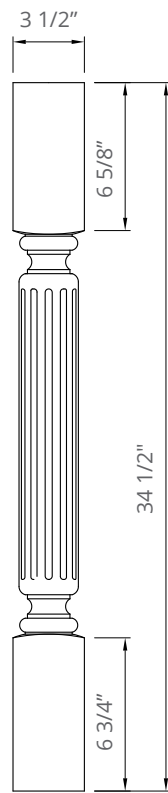

#P201

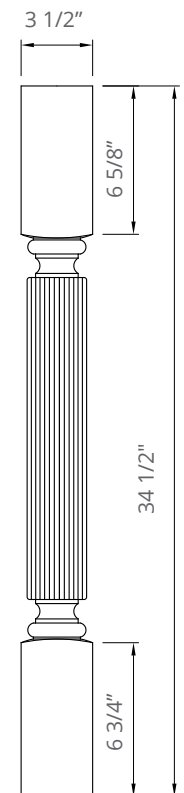

#P202

Turned legs

Available sizes

3" x 3"

3 1/2" x 3 1/2"

4" x 4"

Height : 34 1/2"

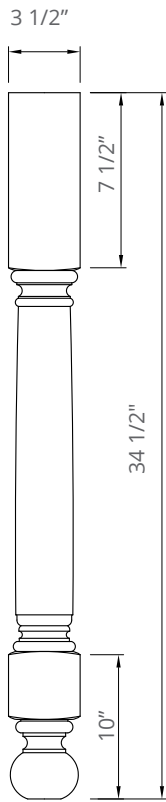

#P105

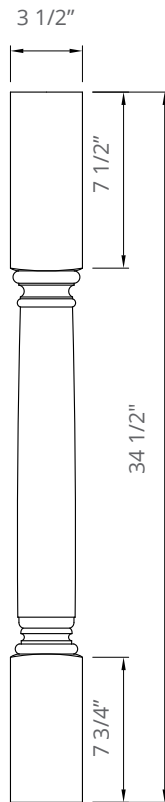

#P106

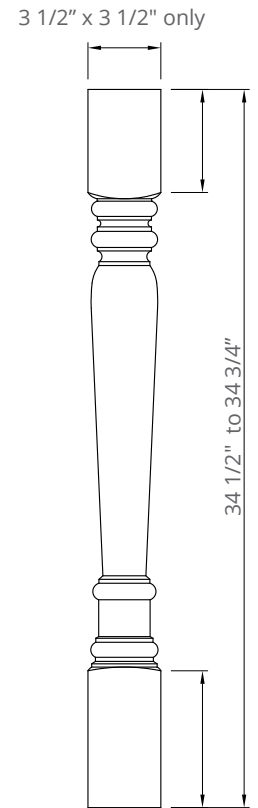

#P402

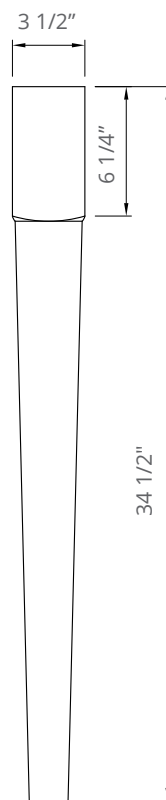

#P108

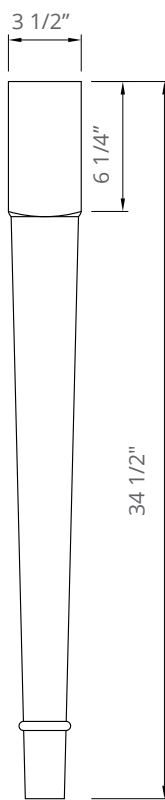

#P109

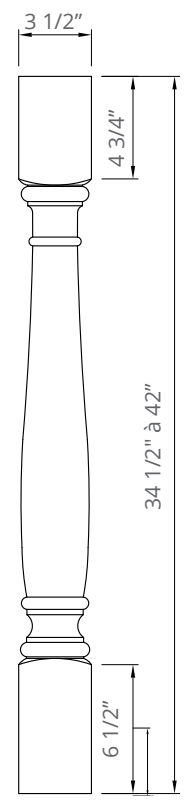

#P405

Turned legs

Available sizes

3 1/2" x 3 1/2"

4" x 4"

Height : 28 1/2", 30 1/2", 34 1/2", 40 1/2"

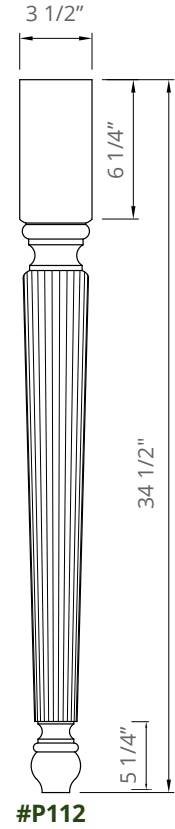
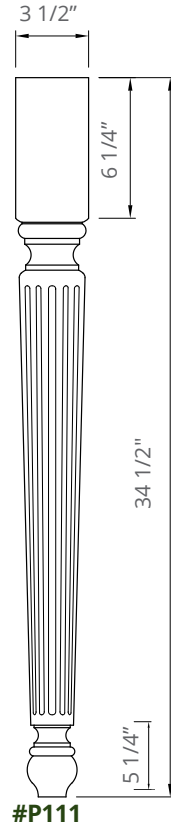
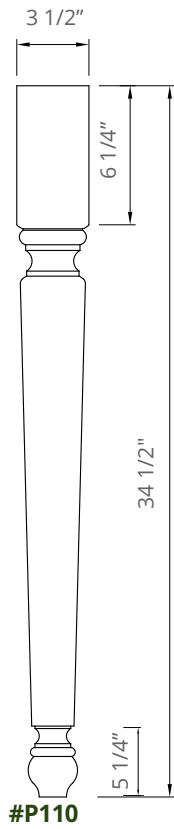

3" x 3"

Height : 24" à 34 1/2"

3 1/2" x 3 1/2"

4" x 4"

Height : 24" à 42"

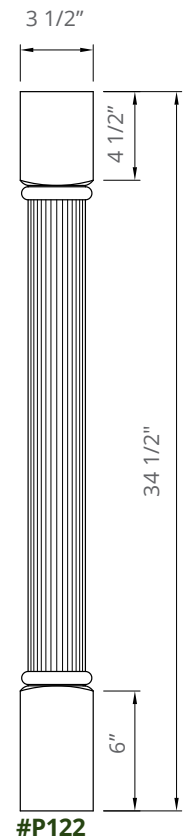
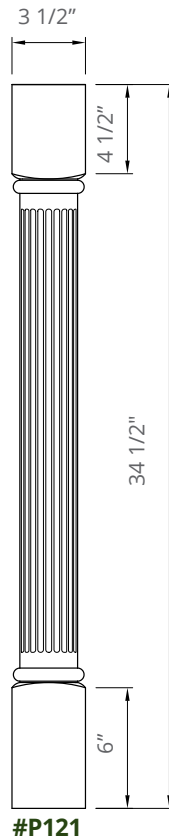
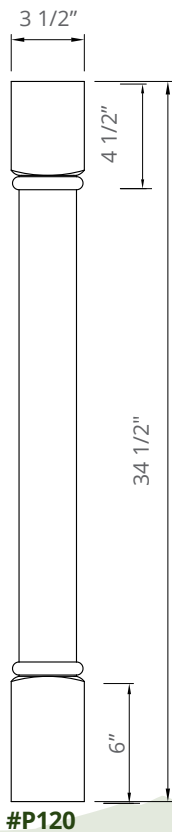

Bunfeets

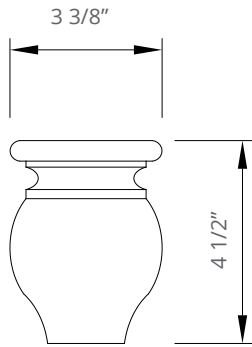

#BF112

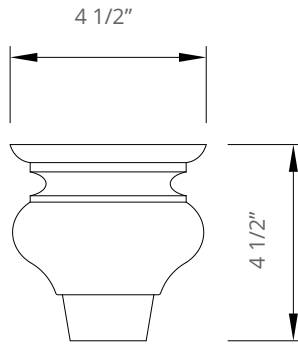

#BF115

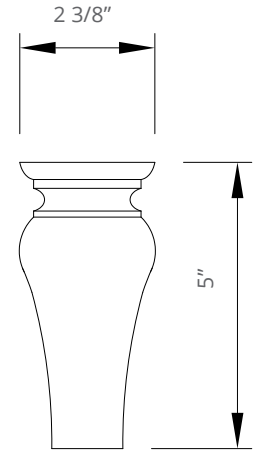

#BF119

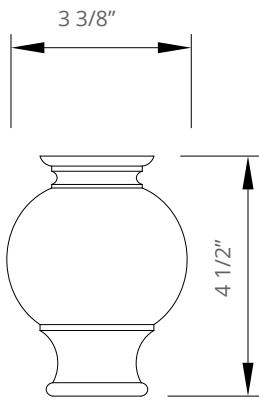

#BF116

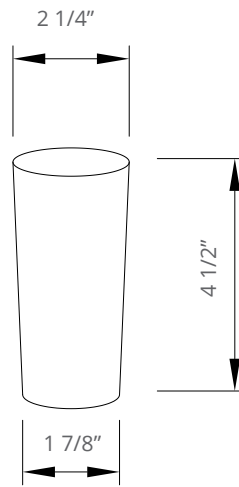

#BF108

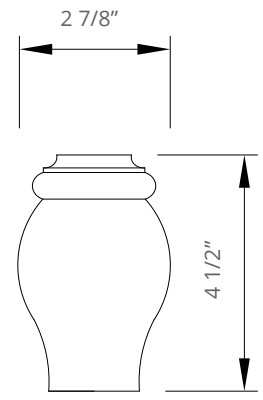

#BF110

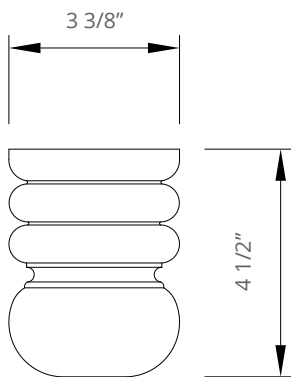

#BF100 (JONH #BF280)

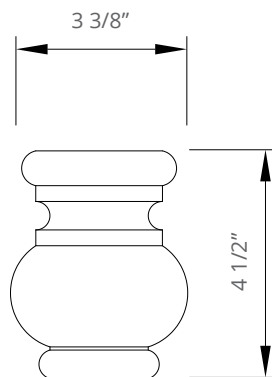

#BF101 (JONH #BF281)

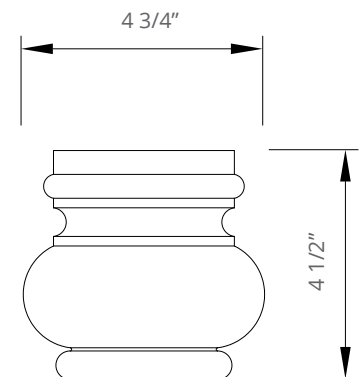

#BF102

Bunfeets

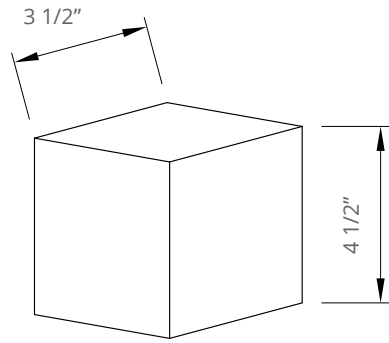

#BF103

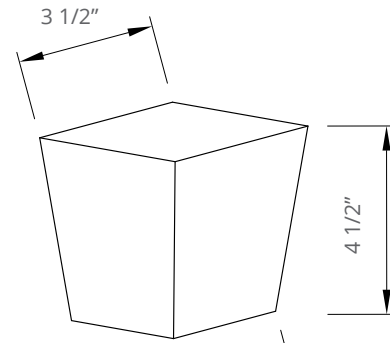

#BF104
Angle on two sides

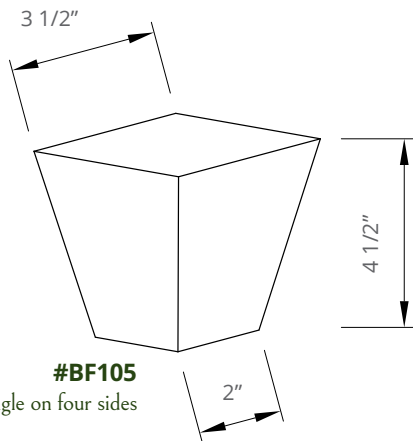

#BF105
Angle on four sides

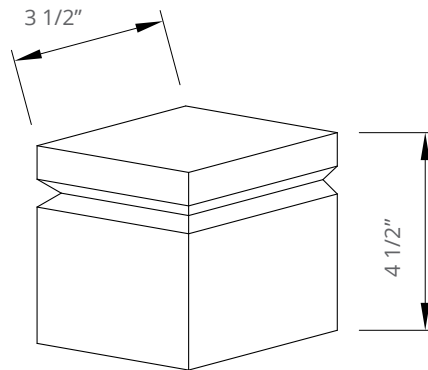

#BF120

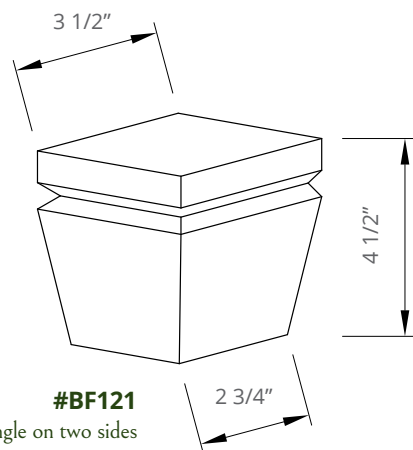

#BF121
Angle on two sides

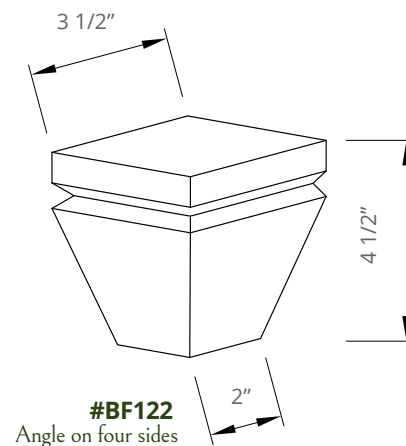

#BF122
Angle on four sides

STORY

In 1979, founder J.O. Noël Houle launched the family business, which at the time focused on the drying and sale of hardwood to cabinetmakers in the region. The quality of its products and service have enabled the company to carve out a place for itself as one of the leading suppliers of quality wood components in the Quebec region and in certain Canadian provinces.

Since the 2000s, the manufacture of mouldings, wood components, countertops and drawers has been at the heart of the company's development, enabling it to maintain an enviable position in the industry.

ENVIRONMENTAL PHILOSOPHY

At JONH, the environment and the preservation of resources are important issues. The choice of top-quality materials used in the manufacture of moldings and high-end kitchen cabinet components ensures that they will last longer. We strive to reduce over-consumption by offering products that stand the test of time. What's more, processing residues are recovered and transformed into animal absorption products and combustible materials.

MISSION

A job well done, the long-term sustainability of our products and respect for the materials we process are the foundations of our company. We like to enter into lasting partnerships with our suppliers and customers. The satisfaction and loyalty of our customers and partners are fundamental to our corporate strategy.

Our passion, our expertise, your satisfaction

4700, Sainte-Catherine
Sherbrooke (Quebec) J1N 0E7
819-864-6273
1-800-565-6273
Fax 819-864-7612
www.mouluresjonh.com

